



INSTALLATION & OPERATION MANUAL

EXPLORE E2



Preface

READ AND FOLLOW ALL INSTRUCTIONS IN THIS MANUAL



CAUTION

(Risk Group 2): Possibly hazardous optical radiation emitted from this product. Do not stare at operating lamp. May be harmful to the eye.



WARNINGS

Before installing your OceanLED Light, read and follow all warning notices and instructions which are included. Failure to follow safety warnings and instructions can result in property damage, severe injury or even death.

Before installing your OceanLED Light, check local laws for restrictions regarding the use of coloured lights in your area.

Do not operate lights out of water for a period longer than 5 minutes followed by an OFF period of at least 1 hour. Exceeding this may cause damage to the light unit.

Ensure the bonding point of the light is fitted to the cathodic protection system on the vessel. Check conductivity between earth bonding point and aluminium bronze front bezel. If mounting the light to metal, wood, or carbon fibre hull, ensure that suitable measures have been put in place to account for the effects of galvanic corrosion i.e., use of Delrin sleeve components (Isolation Kit).

Salt is an inherently corrosive material. Metal parts and certain natural and man-made surfaces are particularly susceptible to corrosion and deterioration when used in and around salt water. Some OceanLED lights contain combinations of plastic and polymer products which are impervious to saltwater corrosion, however, screws and fasteners used for the installation must be of a marine grade type stainless steel or equivalent and monitored annually to ensure the lights remain in service for years to come.

Never connect/disconnect lights with power applied as irreversible damage may occur. Ensure polarity of power connections is correct. Failure to do this may invalidate warranty.

Ensure front of lights are always fully submerged and not fitted on planning / running surfaces that may impact on water since this may damage the product. Also ensure the rear of the light is in a dry area and not subject to a wet environment. Failure to do this may invalidate warranty.

Never Use Solvents! Cleaners, fuel, and other products that may contain strong solvents, such as, but not limited to, acetone, that attack many plastics greatly reducing their strength and irreversibly damaging the special lens coatings and cable sheathings.

Never clean lights using a high-pressure jet wash – this will invalidate warranty.



DANGER

RISK OF ELECTRIC SHOCK OR ELECTROCUTION

This underwater light must be installed by a licensed or certified electrician in accordance with all applicable local codes and ordinances. Improper installation will create an electrical hazard which could result in death or serious injury to swimmers, installers, or others due to electrical shock, and may also cause damage to property. Always disconnect the power to the light at the circuit breaker before servicing the light.

Contents

Preface	1
1 Installation Checklist.....	3
2 Overview.....	4
3 Preparing the Hull.....	5
4 Installation.....	6
4.1 INSTALLING THE LIGHT FIXTURE.....	6
4.2 ELECTRICAL INSTALLATION (12/24V DC).....	10
4.3 FINALISING THE INSTALLATION	13
4.4 TEST YOUR INSTALLATION.....	13
5 Operation / Maintenance.....	14
5.1 SINGLE COLOUR STROBE.....	14
5.2 MAINTENANCE	14
5.3 LIGHT CARTRIDGE REMOVAL.....	14
5.4 LIGHT CARTRIDGE RE-INSTALLATION.....	15
5.5 REPLACEMENT PARTS	15
6 Troubleshooting.....	16
6.1 TROUBLESHOOTING PROBLEMS AND THEIR SOLUTIONS	16
7 Appendix.....	18
7.1 OVERALL DIMENSIONS.....	18
7.2 ESSENTIAL TEST	19
7.3 CABLE GAUGE CHART 12V	20
7.4 CABLE GAUGE CHART 24V	21
8 Warranty	23

PRETEST

Always test the lights prior to installation. Failure to do this may result in additional installation time and could invalidate the warranty. Never leave lights ON out of water for longer than 5 minutes followed by an off period of 1 hour.

IMPORTANT NOTICE

Attention Installer: This manual contains important information about the installation, operation, and safe use of this product. This information should be given to the owner and/ or operator of this equipment.

WARRANTY COVERAGE

Please refer to www.oceanled.com/warranty for full warranty statement.

1 Installation Checklist

1. Decide on light spacing – OceanLED recommendations available.
Rear of lights must never be exposed to wet environments inside the hull.
2. Ensure correct cable gauge is used (refer to relevant cable gauge chart).
3. Preparing the hull (Isolation kit required for conductive hull materials or wooden hulls). Ensure hull thickness is below the maximum 60mm (2.36")
4. Make sure the lights have been fitted following the correct orientation.
5. Correct marine sealant applied evenly around bezel.
Ensure fully watertight seal is created after sealant cures.
6. Correct clamping of light fixture onto hull. Never leave vessel unchecked for a few days after install.
Always check routinely for a few days after installation to ensure the install is correct and fully sealed.
7. Light(s) correctly bonded and vessel bonding system check carried out (refer to relevant schematic and test procedures).
8. Test installation BEFORE entering water. Never connect/ disconnect lights whilst powered ON.
Never leave lights ON out of water for longer than 5 minutes followed by an off period of 1 hour.
9. Troubleshooting if required - most issues can be resolved by following the guidelines.

2 Overview

Identifying your model



Explore E2 Single Colour Narrow Beam



Explore E2 Single Colour Wide Beam

Product components breakdown

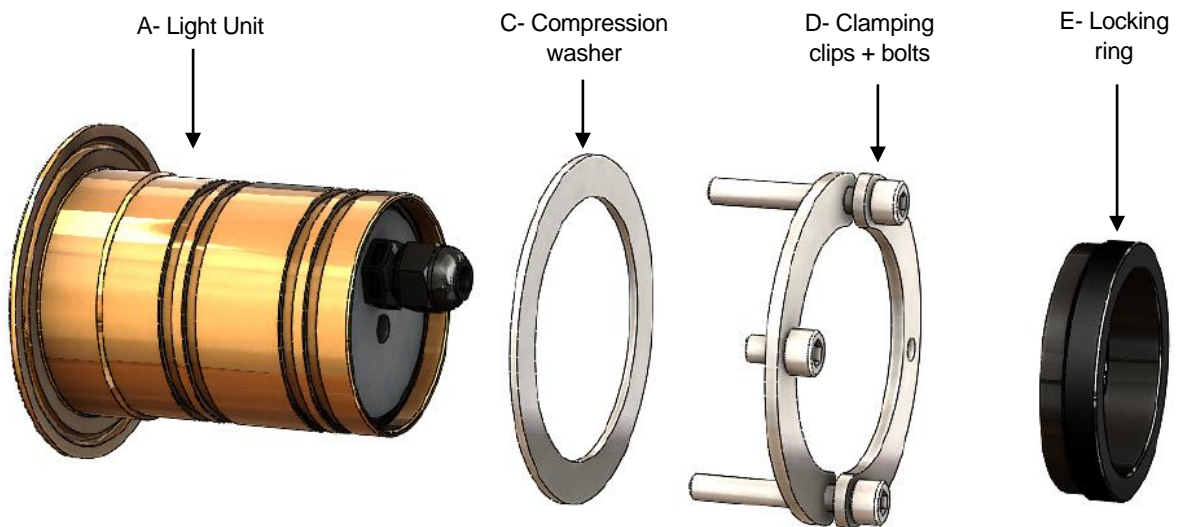

Power Source

Most installations will utilize on-board 12/24V DC power supply from a marine battery. However, if AC to DC power supply is being used, please allow at least 15% reserve for voltage fluctuations due to variables beyond your control such as ambient temperature and supply voltage fluctuations. This is to ensure your lights are always receiving the proper voltage and to ensure the power supply is not “overloaded”, causing premature failure. Use chart below in determining power supplies.

Power Consumption and Recommended Fuse values

Model	Current @ 12V DC	Current @ 24V DC	Max Nominal Power consumption	15% reserve in Watts	Recommended fuse 12V/24V DC
E2 Ultra White	3.5A	1.5A	42W	50W	4A
E2 Midnight Blue	3.5A	1.5A	42W	50W	4A

3 Preparing the Hull

 When installing an Explore unit, please ensure there is enough space on the inside of the vessel to remove the insert for maintenance/after sales services. The XFM unit requires an additional 120mm / 4.7” from the rear of the mounting tube to allow the insert to be removed for maintenance. (See overall dimensions in the Appendix).

Ensure that the part of the light inside the vessel has a diameter of 100mm/ 4” around it free from any insulation material.

OceanLED recommends using a qualified installer / technician when making modifications to your vessel. Please also consult the manufacturer for more detail on modifications and installation.

If lights are assembled in a conductive or wooden hull, an Isolation Kit must be used. Contact OceanLED for additional details.

Depth/Spacing

Ideally mount your lights at similar depth levels to ensure matching colour consistency through the water. Deeper lights will look duller and possibly differ in colour compared to shallower mounted units.

SPACING / INSTALL DEPTH	E2
Recommended Spacing	1-1.5m (3-5')
Recommended Installation depth (From the light waterline)	100-200mm (4-8")

Maximum Hull Thickness

Maximum hull thickness: 60mm (2.36")

Hole Cut Out

Hole Cut out size - 62mm (2.44") / With Isolation Kit 64mm (2.5")

Overall Dimensions

See overall dimension schematic – in the Appendix, Chapter 7.

4 Installation

4.1 INSTALLING THE LIGHT FIXTURE

Explore E2

Kit Includes



Explore E2



Clamping Kit

Additional items required not supplied by OceanLED:

- Marine sealant - 3M 4200 or equivalent
- Cable ties
- Waterproof Cable Connectors / Junction Box (optional)
- Allen key (5mm)
- Thread lock - Loctite 243 or equivalent.

! **DO NOT remove** the light cartridge from the mounting tube during installation. The light cartridge **MUST** stay fitted inside the mounting tube throughout the installation process to avoid the introduction of potential contaminants that may damage the product and void warranty. The light cartridge can only be removed for maintenance or after sales purposes and OceanLED must be contacted prior to any light cartridge being removed from the mounting tube.

🔧 OceanLED recommends dry fitting all products. When installing, be sure that the light fits the area and secures to the hull using the appropriate hardware before applying any sealant.

🔧 When applying sealant to the light fixture, use OceanLED packaging material such as the light cardboard box when placing the light on the ground face down to prevent lens damage.

Installation (Once hull preparation is complete)

1. Test light(s) before fitting into the hull.
2. If using a Delrin Isolation Kit, insert the Isolation Kit front washer into the drilled hole and apply marine sealant to seal between the Front Washer and the hull. The Front Washer is identified by a raised edge and the Rear Washer is flat.

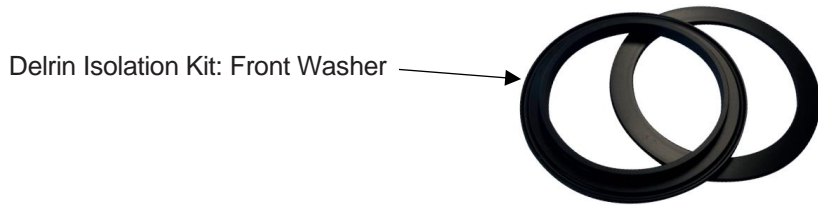

3. Apply marine sealant to the rear of the mounting tube assembly's bezel to ensure a complete unbroken seal around the light.



Make sure sealant fills in the recess groove on the reverse of the light bezel:

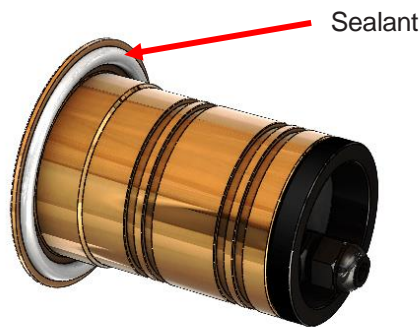

4. Ensure the light orientation is correct with the cable gland at the back positioned at the bottom (see image below) perpendicular to the waterline. If there is not enough space at the back of the light for the cable, the light orientation can be changed to the cable gland positioned at the top, perpendicular to the waterline.

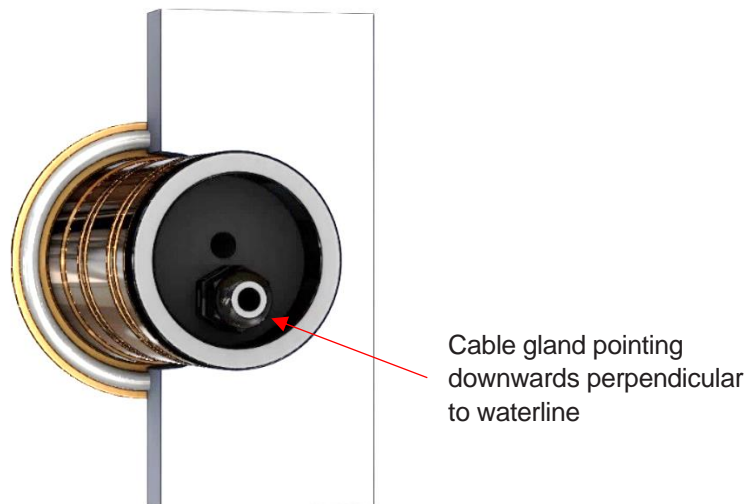

5. Insert the complete light unit (mounting tube assembly + light cartridge) into the hull, pressing the light hard into the hull and twist slightly to spread the sealant around behind the light to ensure good adhesion.

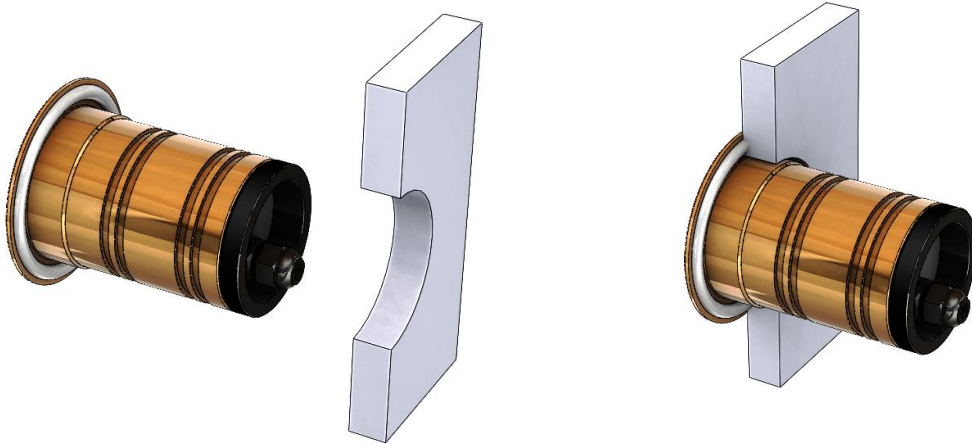

 **This process is made much easier if a second person is inside the hull to receive the light and install the locking equipment whilst supporting the light from the outside. Breakages due to lights falling out of the hull are NOT covered under warranty and can cause serious bodily injury as can any falling object.**

6. If using a Delrin Isolation Kit, insert the Isolation Kit Rear washer over the mounting tube and locate it flush with the hull. The Rear washer is identified as flat.

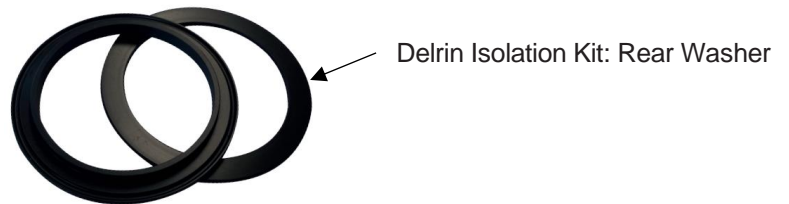

7. Insert the stainless-steel compression washer over the mounting tube.

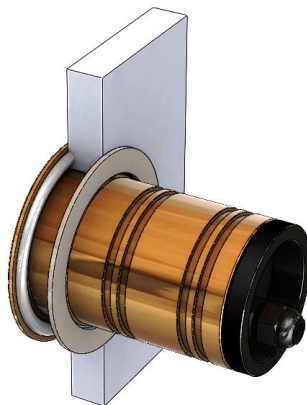

 **The stainless-steel compression washer does not need to be flat to the hull, a slightly uneven surface can be compensated by the washer.**

- Place the two clamping clips together to form a circle, ensuring you pair 1 threaded and 1 non-threaded hole together. Fix the clips together using one of the longer screws provided so that the clips are located approximately halfway down the length of the screw. Locate the clips into the appropriate grooves (depending on hull thickness) on outside of the mounting tube so that the end of the screw is close to the washer. Fit the second longer screw provided into the remaining holes, fixing the two clips together. Leave the shorter screw out to connect the light to the vessel's cathodic protection system.



- Tighten the locking screws using a 5mm Allen key, applying thread lock at point of thread contact with locking ring. **DO NOT** over-tighten locking screws, as you could damage the mounting tube, and this will not be covered under warranty.

Once you are satisfied that the unit is fully tightened, you will notice that sealant has squeezed out from around the perimeter of the light. Using a thinner or cleaner, apply to cloth and wipe off excess sealant to leave a clean seal. **AVOID CONTACT WITH LENS.** If you do not see sealant squeeze out from the body, you have not used enough sealant or tightened the unit enough to the hull. Carefully examine the installation to make sure the seal you have installed on the unit is fully watertight. If in doubt, remove light, re-apply sealant and re-install.

- Connect the bonding cable to the remaining screw and lock in place with shake-proof washer provided. Tighten the locking screw using a 5mm Allen key, applying thread lock at point of thread contact with the clamping clips.

BONDING: The light **MUST** be attached to the vessels bonding / cathodic protection system. Once fitted it is mandatory to check that there is full continuity between the vessels cathodic protection system and the outer bezel of the mounting tube assembly (see bonding schematic – Appendix Chapter 7).



4.2 ELECTRICAL INSTALLATION (12/24V DC)

Explore E2

Kit Includes



Fuse Kit

Additional items required not supplied by OceanLED:

- Junction box* / waterproof connectors
- Sufficient cable to connect to DC Power Pack

*Optional 4-Way Junction box available from OceanLED. Please contact OceanLED or your representative for further information.



Always consult a qualified electrician when connecting OceanLED light fixtures.

When connecting light units, please note that all OceanLED lights will operate within a specific voltage range. Please check the electrical information to ensure cable gauge follow the recommendations.

Never leave the bare cables unprotected. Take care to not leave the bare wire ends in bilge water before making the waterproof connections. Water deposits in the connectors and cables will cause corrosion. Over time water can also work its way into the unit along the inside of the cable due to capillary action causing the light to fail. This will NOT be covered under warranty.



For complete instructions on DC connections, please refer to ABYC codes of practice and other applicable codes and ordinances for DC connections.

Where multiple lights are fitted, and especially on 12V systems, it is advised to use a relay system to supply the switched power to the lights, to reduce load on the switch and voltage drops caused by long cable runs to the switch location.

1. Depending on the model and number of lights installed, you will need to pull the correct sized power cable from the DC power source (breaker/fuse panel) to the light locations to supply constant power to the light units. It is imperative that the correct sized tinned marine grade cable is used to avoid voltage drop issues.

See Chapter 7: Appendix for recommended cable gauges.

2. Using waterproof Butt Splices or IP66 waterproof junction boxes, make the connections at either end of the system to attach the lights to the DC system. Make sure any heatshrink used completely encapsulates the outer wire sheath (the use of glue-lined heat shrink is highly recommended to ensure water tightness).



Never install a new light fixture then leave the vessel in the water unchecked for several days.

3. It is imperative that either the OceanLED supplied fuse on each power line to each light or a suitable protection device is used to protect the cable/light unit. Failure to do so will void the warranty. See table in Chapter 2: Power Consumption and Recommended Fuse values. Make sure any heatshrink used completely encapsulates the outer wire sheath (the use of glue-lined heat shrink is highly recommended to ensure water tightness).
4. Secure cables ensuring where the cable exits the light it is not under undue stress. Finish and test the light units **BEFORE** the vessel goes into the water. Never leave lights ON out of water for longer than 5 minutes followed by an off period of 1 hour.

Fuse Kit Connection Overview:

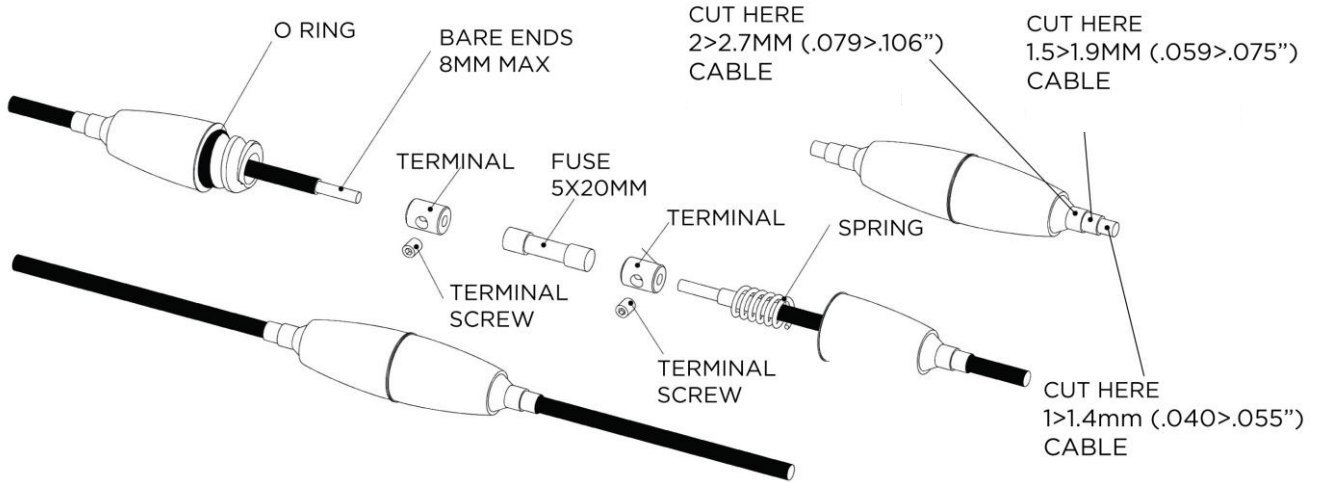

12/24V DC Connection Diagram:

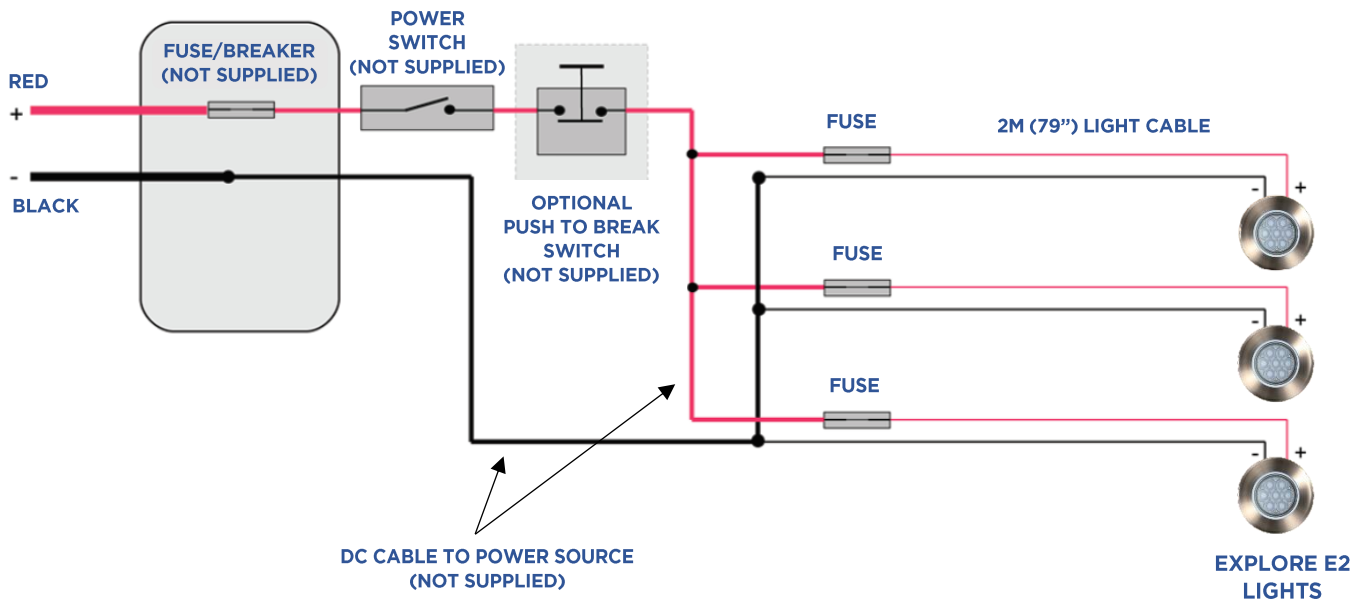

WIRING SCHEMATIC WITH POWER JUNCTION BOX:

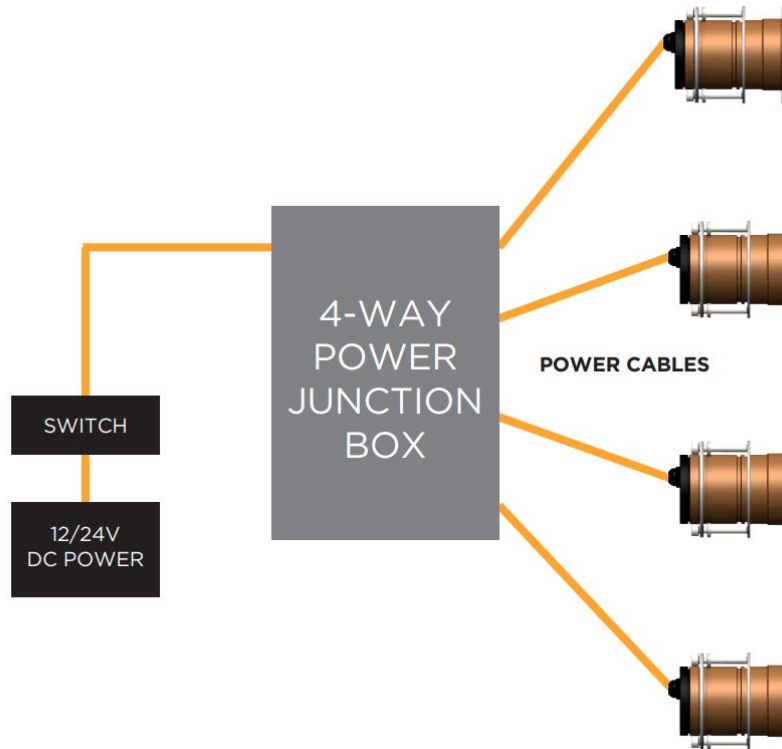

WIRING SCHEMATIC WITH 3RD PARTY JUNCTION BOX:

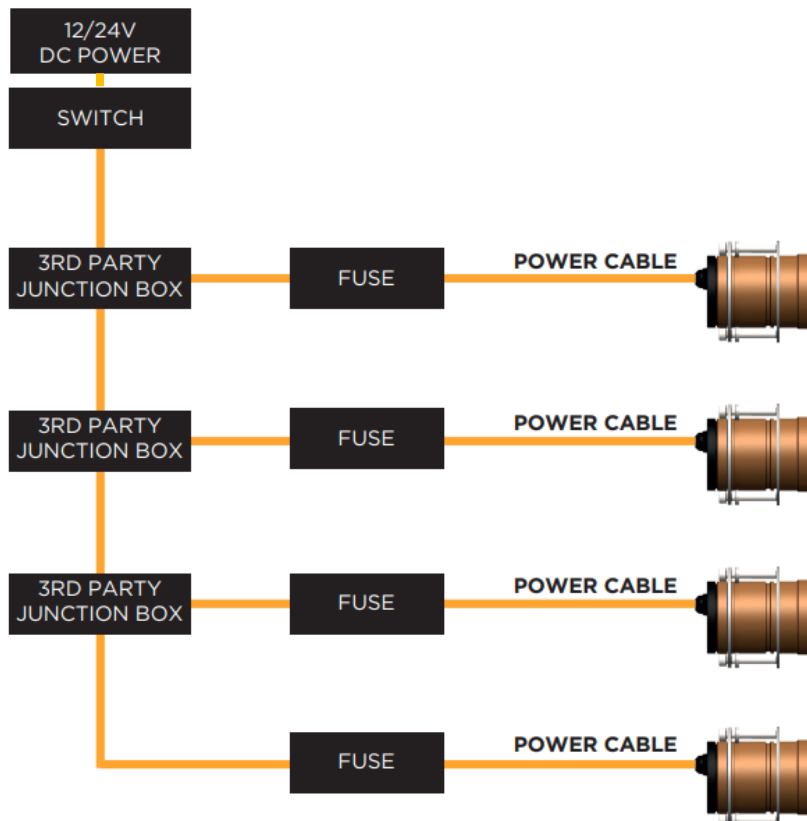

4.3 FINALISING THE INSTALLATION

The Explore XFM mounting tube is constructed from corrosion resistant Aluminium Bronze and does not require further protection. The glass is pre-coated with a specialized Tritonium® coating which helps to prevent marine growth from adhering to the glass.

No paint or any type of anti-fouling agent should be applied to the glass and/or bezel, as damage may occur to the light due to chemical incompatibility and will immediately void the warranty. However, if bottom painting of the bezel is deemed essential, then an area of at least 5mm should be left uncoated around the glass lens:

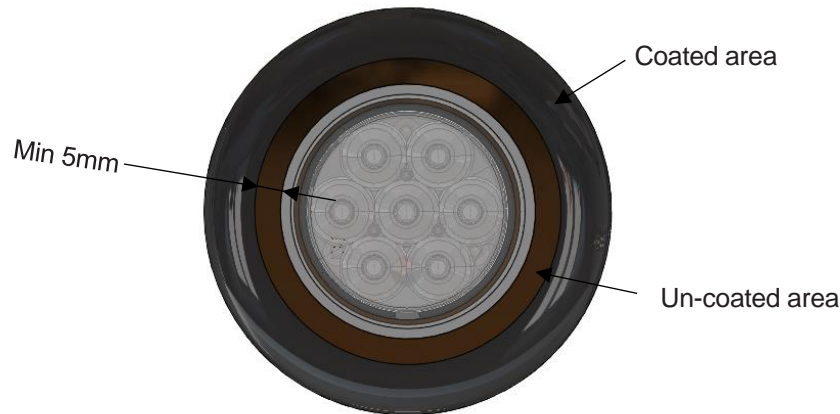

The protective lens sticker should be removed once all work on the vessel is complete.



Please do not use any un-authorized cleaning products to remove excess paint or antifoul off the glass or within 5mm of the glass. OceanLED recommends using Isopropyl Alcohol (IPA) only.

4.4 TEST YOUR INSTALLATION

Always test the lights **BEFORE** the vessel goes back into the water. At this final stage make sure all of the system is operational. If you have any issues, please contact your local OceanLED representative.



Never install a new light fixture then leave the vessel in the water unchecked for several days. Never leave lights ON out of water for longer than 5 minutes followed by an off period of 1 hour.

When the vessel is placed in the water, immediately check for leaks. Note that very small leaks may not be readily observed. It is best not to leave the vessel in the water for more than 3 hours before checking it again. If there is a small leak, there may be considerable bilge water accumulation after 24 hours. If a leak is observed, you must TAKE ACTION IMMEDIATELY to prevent damage.

5 Operation / Maintenance

5.1 SINGLE COLOUR STROBE

To enter strobe mode, with the light on, toggle the power off then quickly back on. They should now strobe in a random pattern. The lights can be reset from strobe mode by simply turning off, waiting 10 seconds, then turn on again.

5.2 MAINTENANCE

Marine growth can build up quickly on the light and can reduce the light's performance in just a few weeks.

To help prevent this, all OceanLED lights have been coated with a specialized Tritonium® coating which helps to prevent marine growth from adhering to the glass. Lights should be cleaned with a boat brush or similar bi-weekly, or as needed to keep the lens of the light clean.

Growth varies greatly around the world and maintenance is imperative to the proper operation and longevity of the product. If heavy fouling occurs, growth can be removed from the lens using a plastic scraper and moderate pressure under water. If cleaning the lens while the boat is out of the water, wet the lens before scraping. Never scrape or try to remove barnacles from a dry lens.

! Never use high pressure jet wash to clean the lens / bezel as this will damage the seals and void the warranty

5.3 LIGHT CARTRIDGE REMOVAL

! Before proceeding with this operation, you **MUST** seek permission from either the manufacturer or your OceanLED representative or you will void the warranty.

DO NOT remove the light cartridge from the mounting tube during installation. The light cartridge **MUST** stay fitted inside the mounting tube throughout the installation process to avoid the introduction of potential contaminants that may damage the product and void the warranty.

Additional items required not supplied by OceanLED:

- M8 Bolt
 - 13mm Spanner (for the M8 bolt)
1. If the vessel is in water check that the front glass is present and intact. Never remove a cartridge with the vessel in water if damage to the glass lens is suspected.
 2. Turn power off and disconnect the light cable connection from the electrical installation.
 3. Remove the Locking Ring from the mounting tube.
 4. To ease removal process; undo the cable gland nut to allow air to enter the unit and prevent a vacuum being created when removing the light cartridge. Failure to do so could damage the light cartridge.
 5. Fit the M8 bolt into M8 threaded hole on the rear of the light cartridge.
 6. Remove the light cartridge from the mounting tube by pulling the M8 bolt.

5.4 LIGHT CARTRIDGE RE-INSTALLATION

Additional items required not supplied by OceanLED:

- Isopropyl Alcohol (IPA)

 **Before installing the light cartridge, clean the inside of the mounting tube with Isopropyl Alcohol (IPA) cleaner and let it dry. Failure to do this may introduce potential contaminants that may damage the product and void your warranty.**

Lubricant substances of any kind MUST NEVER be used to ease the insertion of the light cartridge into the mounting tube as this will damage the light and void the warranty. Should any help to insert the light cartridge be needed, OceanLED recommend the use of a small quantity of Isopropyl Alcohol sprayed onto the O-Ring on the back of the light cartridge.

1. Inspect the mounting tube and light cartridge to ensure no contaminant (grease, debris, dirt) and/or water are present.
2. Undo the cable gland to act as a breather. Failure to do so will make the installation process significantly harder and could damage the light and void the warranty.
3. Align the light cartridge with the mounting tube. Push the light cartridge in slowly until it bottoms out against the front bezel. Please see **Chapter 4 Installation**.
4. Tighten the cable gland.
5. Fit the Locking Ring.
6. Connect the power cable and test the light. Re-check if the light is pointing the right way up.

5.5 REPLACEMENT PARTS

The light source of this luminaire shall only be replaced by the manufacturer or his service agent or a similar qualified person.

Lost, broken and worn parts can be replaced on request and can be obtained through your local OceanLED representative.

If the external flexible cable of this unit is damaged, contact your local OceanLED representative to arrange for replacement (cable must only be replaced by OceanLED, service agent or a similar qualified person).

6 Troubleshooting

6.1 TROUBLESHOOTING PROBLEMS AND THEIR SOLUTIONS

EXPLORE SERIES			
PROBLEM	CHECK	CAUSE	FIX
Light does not look bright	Check that there is no marine growth on the lens	Marine growth	Clean the lens as per maintenance advice
	Check voltage supply to the light is between 11V and 32V DC (The light will still work between 9 and 11 volts however at reduced brightness)	Voltage is either too high or too low	Investigate reason for high or low voltage and fix
	Check voltage supply is stable and does not fluctuate	Voltage is fluctuating	Investigate reason for voltage fluctuation and fix
	Check that the electrical connections between the light and the supply cable have been made correctly and recommended cable gauge has been used	Poor electrical connection	Remake connection and seal joint correctly
	Confirm all LEDs are illuminated	1 or more LEDs are not working	Contact your dealer.
	Check lights to see if water is present inside the light	Water present	Contact your dealer.
	Check cable connections for corrosion	If corrosion is present	It is not advised to reuse the cable if water is present inside. Contact your dealer for a replacement. This is NOT covered by the warranty
Light has water inside	Check integrity of lens	Light will require replacing	This is not covered by the warranty - Contact your dealer for a replacement light. Only use genuine OceanLED parts
	Check connections to make sure they are not submerged in water	Light will require replacing	This is not covered by the warranty
	Check cable to make sure there is no damage to the cable	Cable will require replacing	This is not covered by the warranty. Only use genuine OceanLED parts
	Checked all factors that are above, and the light still does not work	Light faulty	Contact your dealer for a replacement light

EXPLORE SERIES			
PROBLEM	CHECK	CAUSE	FIX
Light does not light up	Check that the electrical connections between the light and the supply cable have been made correctly	Poor electrical connection	Remake connection and seal joint correctly
	Check that the wiring polarity is correct, red to positive and black to negative	Polarity incorrect	Change the wiring polarity and seal joint correctly
	Check that there is power supply to the light cable connection	Poor electrical connection	Trace the cables back, checking at joints until break has been located. Then rectify the problem and seal joint correctly
	Check that the electrical connections between the supply cable and the light circuit breaker or fuse have been made correctly	Poor electrical connection	Remake connection and seal joint correctly
	Check that the in-line fuse is intact and not blown	Replace fuse	If fuse keeps blowing, then there is a short circuit in the light system that must be traced and rectified. If no external short can be located contact your dealer
	Check that the light supply circuit breaker is closed, or the fuse has not blown	Close circuit breaker / replace fuse	If breaker / fuse keeps blowing, then there is a short circuit in the light system that must be traced and rectified. If no external short can be located contact your dealer

7 Appendix

7.1 OVERALL DIMENSIONS

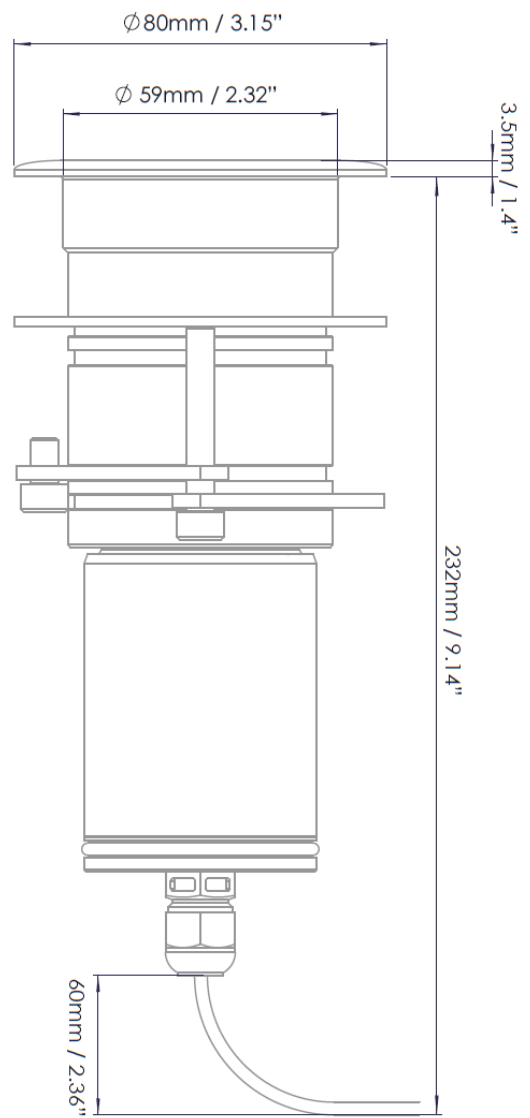
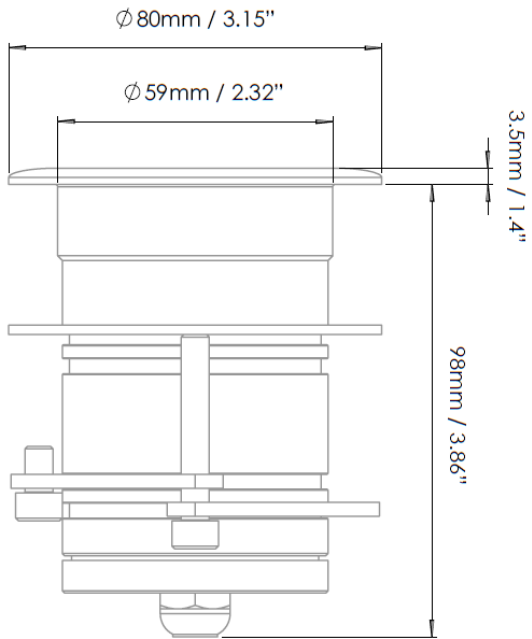

7.2 ESSENTIAL TEST

! Perform this bonding check after installation of the light and before moving the vessel back into the water.

Refer to bonding information in the installation sections in this manual. If in doubt, please contact OceanLED.

1. Connect the light assembly to the cathodic protection system as explained in **Chapter 4**.
2. Measure the electrical continuity between the front bezel and the sacrificial anode. This test should give a reading of up to 0.5Ω (Ohms). This procedure will guarantee electrical continuity between the front bezel, the mounting tube and the sacrificial anode.

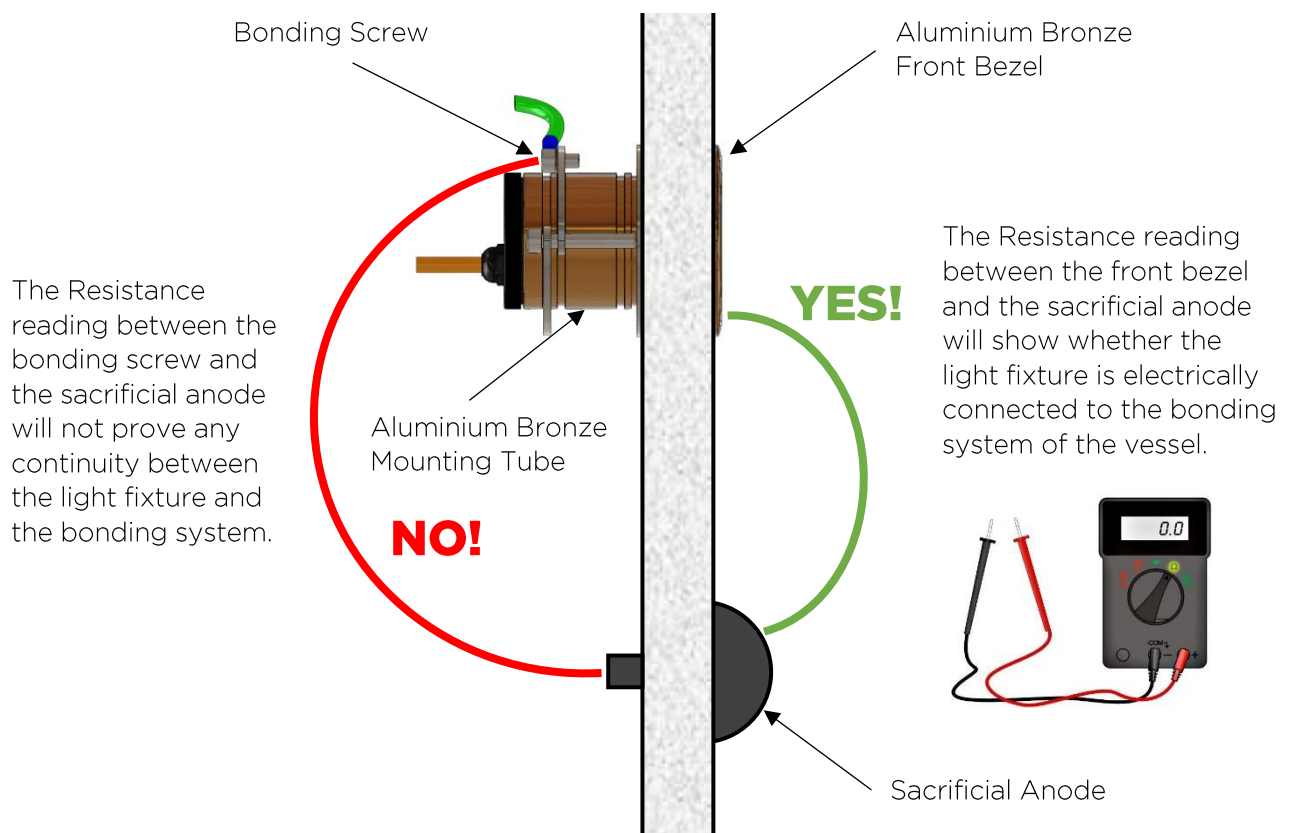

If you have any questions regarding the above, please contact OceanLED:

+44 (0) 1455 637505 or info@oceanled.com

7.3 CABLE GAUGE CHART 12V

Supply & Return Cable Conductor Size Chart 3% drop for when using 12V DC supply

Cable length (feet)*	Circuit Current										
	2 Amp	4 Amp	6 Amp	8 Amp	10 Amp	15 Amp	20 Amp	25 Amp	30 Amp	40 Amp	50 Amps
0-5	18 AWG	18 AWG	16 AWG	16 AWG	14 AWG	12 AWG	12 AWG	10 AWG	10 AWG	8 AWG	8 AWG
5-10	18 AWG	16 AWG	14 AWG	12 AWG	12 AWG	10 AWG	8 AWG	8 AWG	6 AWG	6 AWG	4 AWG
10-15	16 AWG	14 AWG	12 AWG	10 AWG	10 AWG	8 AWG	6 AWG	6 AWG	4 AWG	4 AWG	2 AWG
15-20	16 AWG	12 AWG	10 AWG	10 AWG	8 AWG	6 AWG	6 AWG	4 AWG	4 AWG	2 AWG	2 AWG
20-25	14 AWG	12 AWG	10 AWG	8 AWG	8 AWG	6 AWG	4 AWG	4 AWG	2 AWG	2 AWG	1 AWG
25-30	14 AWG	10 AWG	10 AWG	8 AWG	6 AWG	4 AWG	4 AWG	2 AWG	2 AWG	1 AWG	0 AWG
30-35	14 AWG	10 AWG	8 AWG	8 AWG	6 AWG	4 AWG	4 AWG	2 AWG	2 AWG	1 AWG	0 AWG
35-40	12 AWG	10 AWG	8 AWG	6 AWG	6 AWG	4 AWG	2 AWG	2 AWG	1 AWG	0 AWG	2/0 AWG
40-45	12 AWG	10 AWG	8 AWG	6 AWG	4 AWG	4 AWG	2 AWG	2 AWG	1 AWG	0 AWG	2/0 AWG
45-50	12 AWG	8 AWG	6 AWG	6 AWG	4 AWG	2 AWG	2 AWG	1 AWG	0 AWG	2/0 AWG	3/0 AWG
50-55	12 AWG	8 AWG	6 AWG	6 AWG	4 AWG	2 AWG	2 AWG	1 AWG	0 AWG	2/0 AWG	3/0 AWG
55-60	10 AWG	8 AWG	6 AWG	4 AWG	4 AWG	2 AWG	1 AWG	0 AWG	0 AWG	3/0 AWG	4/0 AWG
60-65	10 AWG	8 AWG	6 AWG	4 AWG	4 AWG	2 AWG	1 AWG	0 AWG	2/0 AWG	3/0 AWG	4/0 AWG
65-70	10 AWG	8 AWG	6 AWG	4 AWG	4 AWG	2 AWG	1 AWG	0 AWG	2/0 AWG	3/0 AWG	4/0 AWG
70-75	10 AWG	6 AWG	4 AWG	4 AWG	2 AWG	2 AWG	0 AWG	2/0 AWG	2/0 AWG	4/0 AWG	
75-80	10 AWG	6 AWG	4 AWG	4 AWG	2 AWG	1 AWG	0 AWG	2/0 AWG	3/0 AWG	4/0 AWG	
80-85	10 AWG	6 AWG	4 AWG	4 AWG	2 AWG	1 AWG	0 AWG	2/0 AWG	3/0 AWG	4/0 AWG	
85-90	10 AWG	6 AWG	4 AWG	4 AWG	2 AWG	1 AWG	0 AWG	2/0 AWG	3/0 AWG	4/0 AWG	
90-95	8 AWG	6 AWG	4 AWG	2 AWG	2 AWG	1 AWG	2/0 AWG	3/0 AWG	3/0 AWG		
95-100	8 AWG	6 AWG	4 AWG	2 AWG	2 AWG	0 AWG	2/0 AWG	3/0 AWG	4/0 AWG		

*One-way cable length from supply (usually battery) to load.

7.4 CABLE GAUGE CHART 24V

Supply & Return Cable Conductor Size Chart 3% drop for when using 24V DC supply											
Cable length (feet)*	Circuit Current										
	2 Amp	4 Amp	6 Amp	8 Amp	10 Amp	15 Amp	20 Amp	25 Amp	30 Amp	40 Amp	50 Amps
0-5	18 AWG	18 AWG	18 AWG	18 AWG	18 AWG	16 AWG	14 AWG	14 AWG	12 AWG	12 AWG	10 AWG
5-10	18 AWG	18 AWG	16 AWG	16 AWG	14 AWG	12 AWG	12 AWG	10 AWG	10 AWG	8 AWG	8 AWG
10-15	18 AWG	16 AWG	14 AWG	14 AWG	12 AWG	12 AWG	10 AWG	8 AWG	8 AWG	6 AWG	6 AWG
15-20	18 AWG	16 AWG	14 AWG	12 AWG	12 AWG	10 AWG	8 AWG	8 AWG	6 AWG	6 AWG	4 AWG
20-25	18 AWG	14 AWG	12 AWG	12 AWG	10 AWG	8 AWG	8 AWG	6 AWG	6 AWG	4 AWG	4 AWG
25-30	16 AWG	14 AWG	12 AWG	10 AWG	10 AWG	8 AWG	6 AWG	6 AWG	4 AWG	4 AWG	2 AWG
30-35	16 AWG	14 AWG	12 AWG	10 AWG	10 AWG	8 AWG	6 AWG	6 AWG	4 AWG	4 AWG	2 AWG
35-40	16 AWG	12 AWG	10 AWG	10 AWG	8 AWG	6 AWG	6 AWG	4 AWG	4 AWG	2 AWG	2 AWG
40-45	14 AWG	12 AWG	10 AWG	10 AWG	8 AWG	6 AWG	4 AWG	4 AWG	4 AWG	2 AWG	2 AWG
45-50	14 AWG	12 AWG	10 AWG	8 AWG	8 AWG	6 AWG	4 AWG	4 AWG	2 AWG	2 AWG	1 AWG
50-55	14 AWG	12 AWG	10 AWG	8 AWG	8 AWG	6 AWG	4 AWG	4 AWG	2 AWG	2 AWG	1 AWG
55-60	14 AWG	10 AWG	10 AWG	8 AWG	6 AWG	4 AWG	4 AWG	2 AWG	2 AWG	1 AWG	0 AWG
60-65	14 AWG	10 AWG	8 AWG	8 AWG	6 AWG	4 AWG	4 AWG	2 AWG	2 AWG	1 AWG	0 AWG
65-70	14 AWG	10 AWG	8 AWG	8 AWG	6 AWG	4 AWG	4 AWG	2 AWG	2 AWG	1 AWG	0 AWG
70-75	12 AWG	10 AWG	8 AWG	6 AWG	6 AWG	4 AWG	2 AWG	2 AWG	2 AWG	0 AWG	2/0 AWG
75-80	12 AWG	10 AWG	8 AWG	6 AWG	6 AWG	4 AWG	2 AWG	2 AWG	1 AWG	0 AWG	2/0 AWG
80-85	12 AWG	10 AWG	8 AWG	6 AWG	6 AWG	4 AWG	2 AWG	2 AWG	1 AWG	0 AWG	2/0 AWG
85-90	12 AWG	10 AWG	8 AWG	6 AWG	4 AWG	4 AWG	2 AWG	2 AWG	1 AWG	0 AWG	2/0 AWG
90-95	12 AWG	8 AWG	8 AWG	6 AWG	4 AWG	4 AWG	2 AWG	1 AWG	1 AWG	2/0 AWG	2/0 AWG
95-100	12 AWG	8 AWG	6 AWG	6 AWG	4 AWG	2 AWG	2 AWG	1 AWG	0 AWG	2/0 AWG	3/0 AWG

*One-way cable length from supply (usually battery) to load.

8 Warranty

Please remove this page and keep for your files

For technical assistance:

Europe: service@oceanled.com

The Americas: warranty@oceanledusa.com

Warranty Serial Code(s):

© 2022 Ocean LED Marine LTD
All Rights Reserved

Specifications are subject to change without notice.

Trademarks are the property of Ocean LED Marine LTD

Ocean LED Marine LTD

Unit 1 Jacknell Road
Dodwells Bridge Industrial Estate
Hinckley,
Leicestershire LE10 3BS
United Kingdom

Tel: +44 (0) 1455 637505
Fax: +44 (0) 1455 238553
sales@oceanled.com

Ocean LED USA LLC

778 South Military Trail
Deerfield Beach
Florida
FL 33442-3025
USA

Tel: +1 954.523.2250
Fax: +1 954.523.2249
sales@oceanledusa.com

www.oceanled.com